

SPECIFICATION

Product Name: Laser Particle Counting Sensor Item

No.: PM3003SN.

Version: V0.2

Date: 6th Sept, 2023

Revision

No.	Version	Content	Date
1	V0.1	First version	2021.01.21
2	V0.2	Revise specification parameter	2023.09.06

Laser Particle Counting Sensor

PM3003SN



Applications

- Clean Room
- Pharmaceuticals Industry
- Electronics industry
- Microbiological Industry

Description

The PM3003SN laser dust particle counting sensor is based on the principle of light scattering, which can accurately detect and calculate the number of suspended particles of different particle sizes per unit volume of air. It can output the particle counts of six channels of 0.3 μ m, 0.5 μ m, 1.0 μ m, 2.5 μ m, 5.0 μ m, and 10 μ m at the same time.

Features

- 6-channel (0.3 μ m, 0.5 μ m, 1.0 μ m, 2.5 μ m, 5.0 μ m, 10 μ m) simultaneous particle numbers output in pcs/L(default), pcs/m³, pcs/28.3L
- Constant power line laser, precise identification
- Concave condensing design, high counting efficiency
- Wide working temperature range, more stability
- Good EMC compatibility, strong antistatic ability
- Continuous online measurement mode and single accumulative counting mode

Working Principle

The sensor is generated negative pressure by external device for air sampling. When the particles in the sample gas pass through the condensed beam of the light source (laser), light scattering occurs. The scattered light is converted into an electrical signal (pulse) through the photoelectric converter. The larger the particle, the larger the pulse signal (peak value). The quantity of each particle size can be obtained by the peak value and the number of pulses at the same time.

Specifications

Laser Particle Counting Sensor PM3003SN Specification	
Operating principle	Laser scattering
Output channels	>0.3μm, >0.5μm, >1.0μm, >2.5μm, >5.0μm, >10μm
Measurement range	0~10,000,000 pcs/L (1pcs/L=28.3pcs/cf)
Working condition	-30°C ~ 70°C, 0-95%RH (non-condensing)
Storage condition	-40°C ~ 85°C, 0-95%RH (non-condensing)
Measurement error	<100pcs/l: ± 30pcs/L >100pcs/L: ± 30% of reading Condition: 0C ~ 40C,50+10%RH (0°C ~ 40°C, 50 ±10%RH. Reference instrument TSI 9306. TSI 9306 count efficiency 50% @ 0.3 μm and 100% for particles >0.45 μm)
Sampling interval	1s
Time to first reading	≤ 8s
Power supply	DC 5V±0.1V Ripple wave < 50mV
Working current	<150mA
Standby current	<25mA
Dimensions	W82*H40.2*D26.3 (mm)
Digital output	UART_TTL/ I ² C (3.3V/5V) ,RS485(can be customized)
Lifetime	≥5 years(continuous working)
Sampling flow rate	2.83L/min (recommended)

Dimensions and Connector

1. Dimensions (Unit: mm)

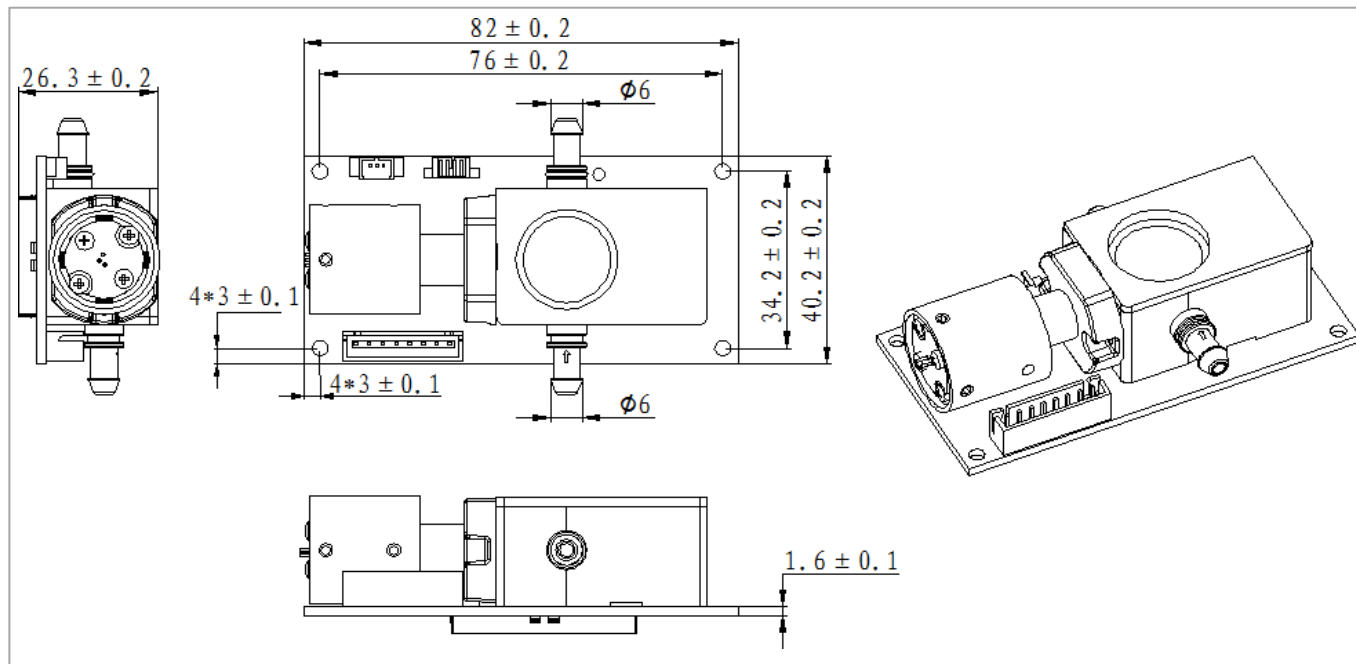

2. I/O Connector Definition

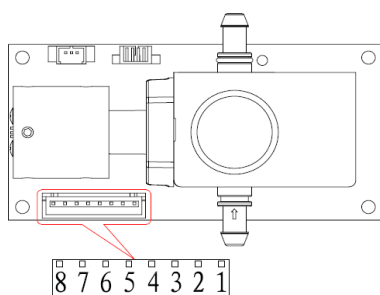

No.	Pin	Description
1	VCC	Power input (+5V)
2	VCC	Power input (+5V)
3	GND	Power input (GND)
4	GND	Power input (GND)
5	TXD /SCL	UART sending (TTL level @3.3V~5V)/ I ² C clock
6	RXD/SDA	UART receiving (TTL level @3.3V~5V)/ I ² C data
7	CTR	Output mode exchange TTL level @3.3V high level or floating is UART communication mode, low level is I ² C communication mode
8	BT	NC

3. Connector Description

The interface connector of Sensor is A2501WV-8P. The pitch is 2.5mm.

The connection cable with female connector at both ends can also be customized.

Typical Application Circuits

Application 1: UART TTL 3.3V output

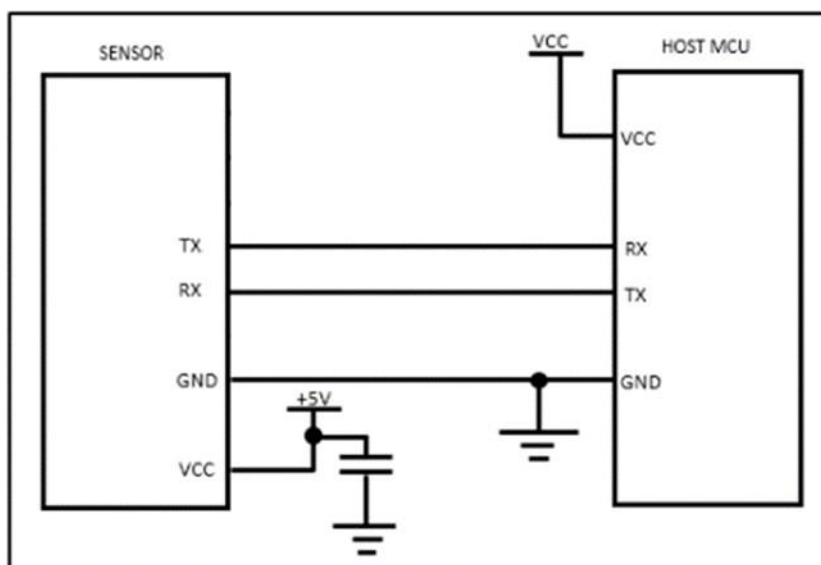

Application 2: I2C TTL 3.3V output

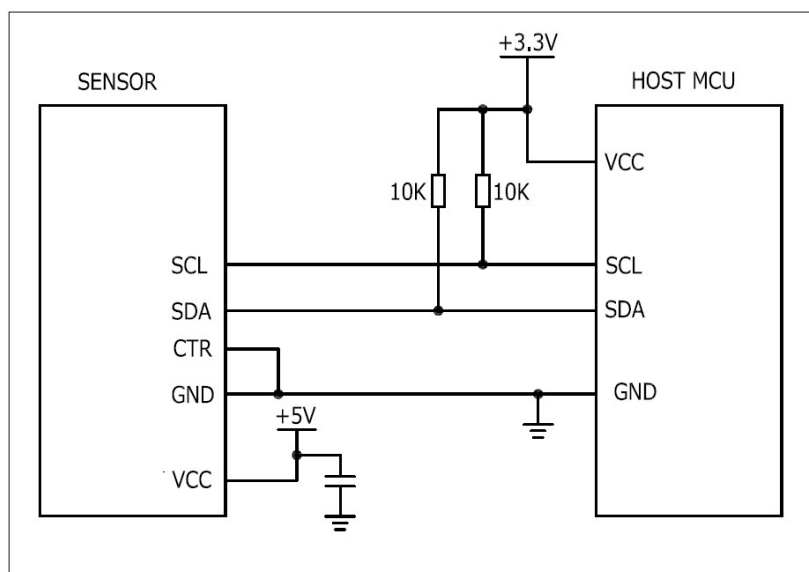

Attention for circuit design:

- UART and I²C communication compatible for 3.3V and 5V voltage level (receiver)
- PIN8 is a floating port, which is used for internal programming only.

UART Communication Protocol

1. General Statement

- 1) The data in this protocol is all hexadecimal data. For example, "46" for decimal [70].
- 2) [xx] is for single-byte data (unsigned, 0-255); for double data, high byte is in front of low byte.
- 3) Baud rate: 9600; Data Bits: 8; Stop Bits: 1; Parity: No
- 4) It is default by continuously mode after powering on.

2. Format of Serial Communication Protocol

Sending format of software:

Start Symbol	Length	Command	Data 1	Data n.	Check Sum
HEAD	LEN	CMD	DATA1	DATAn	CS
11H	XXH	XXH	XXH	XXH	XXH

Detail description on protocol format:

Protocol Format	Description
Start symbol	Sending by software is fixed as [11H], module respond is fixed as [16H]
Length	Length of frame bytes= data length +1 (including CMD+DATA)
Command	Command
Data	Data of writing or reading, length is not fixed
Check sum	Cumulative sum of data = 256- (HEAD+LEN+CMD+DATA)

3. Command Table of Serial Protocol

Item No.	Function Description	Command
1	Read particle measurement result	0x0B
2	Open/close particle measurement	0x0C
3	Set up and read particle calibration coefficient	0x07
4	Set and read output unit	0x15
5	Read serial number	0x1F

4. Detail Description of UART Protocol

4.1 Read Particle Measurement Result

Send: 11 02 0B 07 DB

Response: 16 35 0B DF1- DF52 [CS]

Function: Read measurement result.

Note: Read particles quantity (pcs/L).

Data	Description
DF1~DF4	>0.3μm, particles quantity unit: pcs/m ³
DF5~DF8	>0.5μm, particles quantity, unit: pcs/m ³
DF9~DF12	>1.0μm, particles quantity, unit: pcs/ m ³
DF13~DF16	>2.5μm, particles quantity, unit: pcs/ m ³
DF17~DF20	>5.0μm, particles quantity, unit: pcs/ m ³
DF21~DF24	>10μm, particles quantity, unit: pcs/ m ³
DF25~DF28	>0.3μm, particles quantity, unit: pcs/L(default), can be set as pcs/ m ³ or pcs/28.3L
DF29~DF32	>0.5μm, particles quantity, unit: pcs/L(default), can be set as pcs/ m ³ or pcs/28.3L
DF33~DF36	>1.0μm, particles quantity, unit: pcs/L(default), can be set as pcs/ m ³ or pcs/28.3L
DF37~DF40	>2.5μm, particles quantity, unit: pcs/L(default), can be set as pcs/ m ³ or pcs/28.3L
DF41~DF44	>5.0μm, particles quantity, unit: pcs/L(default), can be set as pcs/ m ³ or pcs/28.3L
DF45~DF48	>10μm, particles quantity, unit: pcs/L(default), can be set as pcs/ m ³ or pcs/28.3L
DF49	Alarm
DF50	Output unit: 0: pcs/L 1:pcs/ m ³ 2:pcs/28.3L
DF51	Reserved: 0: continuous measuring mode 1: single accumulative counting mode
DF52	Sensor status: 1. Shut off 2. Measuring 0x80: measurement completion

>0.3μm, particles quantity = DF1*256³ + DF2*256² + DF3*256¹ + DF4

>0.5μm, particles quantity = DF5*256³ + DF6*256² + DF7*256¹ + DF8

>1.0μm, particles quantity = DF9*256³ + DF10*256² + DF11*256¹ + DF12

>2.5μm, particles quantity = DF13*256³ + DF14*256² + DF15*256¹ + DF16

>5.0μm, particles quantity = DF17*256³ + DF18*256² + DF19*256¹ + DF20

>10μm, particles quantity = DF21*256³ + DF22*256² + DF23*256¹ + DF24

>0.3um, particles quantity = DF25*256³ + DF26*256² + DF27*256¹ + DF28

>0.5μm, particles quantity = DF29*256³ + DF30*256² + DF31*256¹ + DF32

>1.0μm, particles quantity = DF33*256³ + DF34*256² + DF35*256¹ + DF36

>2.5μm, particles quantity = DF37*256³ + DF38*256² + DF39*256¹ + DF40

>5.0μm, particles quantity = DF41*256³ + DF42*256² + DF43*256¹ + DF44

>10μm, particles quantity = DF45*256³ + DF46*256² + DF47*256¹ + DF48

DF49: Alarm of sensor module working condition:

Bit	Bit 7	Bit 6	Bit 5	Bit 4	Bit 3	Bit 2	Bit 1	Bit 0
Alarm definition		1: Laser tube failure alarm		1: Fouling alarm	1: Low temperature alarm	1: High temperature alarm		

4.2 Open/Close Particle Measurement

Send: 11 03 0C DF1 1E CS

Response: 16 02 0C DF1 CS

Function: Open/ close particle measurement

Note:

1. When sending command, DF1=02 means opening measurement, DF1=01 means closing measurement;
2. When receiving response, DF1=02 means measuring opened, DF1=01 means measuring closed;
3. When the sensor receives the command of opening measurement, it will be in default continuous measuring mode.

Example:

Send: 11 03 0C 02 1E C0 //open particle measurement

Response: 16 02 0C 02 DA //module is under particle measurement open status

Send: 11 03 0C 01 1E C1 //close particle measurement

Response: 16 02 0C 01 DB // module is under particle measurement closed status

4.3 Set up and Read Particle calibration coefficient

Send: 11 02 07 DF1 CS // Set up particle calibrated coefficient **Send:**

11 01 07 E7 // Read particle calibrated coefficient **Response:** 16 02

07 DF1 CS

Function: Read/set up particle calibration coefficient

Note:

Calibration coefficient =DF1/100

Calibration coefficient setting valid range: 0.1~2.5.

After calibration coefficient settled, >0.3um、>0.3um、>1um、>2.5um、>5um、>10um particle quantity all corrected by this coefficient.

4.4 Set and read output unit

Send: 11 04 15 00 00 DF1 CS //set output unit

Response: 16 04 15 00 00 DF1 CS

Send: 11 04 15 00 01 00 D5 //read output unit

Response: 16 04 15 00 01 DF1 CS

Note:

Unit pcs/L: DF1=0 Unit

pcs/ m³ : DF1=1 Unit

pcs/28.3L: DF1=2

4.5 Set working mode Send:

11 04 15 0100 DF1 CS

Response: 16 04 15 0100 DF1 CS

4.6 Read working mode

Send: 11 04 15 010100 D4

Response: 16 04 15 0101 DF1 CS

Note:

Continuous counting mode: DF1=0 Single

cumulative counting mode: DF1=1

1. In the continuous counting mode, the sensor is in a continuously turned-on state, and the measured value is the particle value of the current environment. The measurement stops after receiving the close measurement command.
2. In the single cumulative counting mode, the sensor is in the off state, and the measurement starts after receiving the instruction to start the measurement. The measurement value is the continuous accumulated value, and after the measurement time arrives (the output PCS /L will work for 21s, and the output PCS /28.3L will work for 60s. Output PCS /m³ working 300s) automatically close the measurement and output the final particle count value.
3. The set output unit will not be saved after power-off, and need to be reset after power-on
4. When the unit output is set to pcs/28.3L or pcs/L in the single cumulative counting mode, the pcs/ m³ output value will be invalid

4.7 Read Serial Number

Send: 11 01 1F CF

Response: 16 0B 1F DF1 DF2 DF3 DF4 DF5 DF6 DF7 DF8 DF9 DF10 CS

Function: Read serial number

Note:

Serial number = (DF1*256+DF2), (DF3*256+DF4), (DF5*256+DF6), (DF7*256+DF8), (DF9*256+DF10)

Example:

Response: 16 0B 1F 00 00 00 7E 09 07 07 0E 0D 72 9E

Serial number: 0000 0126 2311 1806 3442

I²C Communication Protocol

1. Brief Introduction

- a. This is an I²C protocol for PM3003SN. The sensor module is lower computer, which is not able to initiate communication automatically. Communication is initiated via main controlled board, which reads data and sends control commands.
- b. Communication clock frequency $\leq 100\text{KHz}$

2. Communication Common

START: start signal, send by main controlled board; STOP:

stop signal, send by main controlled board;

ACK: acknowledge signal, send by the sensor module if in bold; otherwise, send by main controlled board; NACK:

non-acknowledge signal, send by the sensor module if in bold; otherwise, send by main controlled board; Px:

receive and send data; send by the sensor module if in bold; otherwise, send by main controlled board.

3. Protocol Detailed Description

3.1 Send Command Data

Send by main controlled board: START+WRITE+ACK+P1+ACK+P2+ACK.....

+P7+ACK+STOP

Data	Byte content	Description
Device address	Sensor address and read/write command	This byte is 0x50 when write data
P1	0x16	Frame header
P2	Frame length	Number of byte, not including length of device address (From P1 to P7, 7 bytes in total)
P3	Data 1	Control command of the sensor as: Close measurement: 1 Open measurement: 2 Set calibration coefficient: 6 Set output unit: 8
P4	Data 2, high byte	Calibration coefficient: range 10~250, corresponding coefficient:0.1~2.5
P5	Data 2, low byte	
P6	Data 3	Set output unit: 0:pcs/L 1:pcs/ m ³ 2:pcs/28.3L
P7	Data check code	Check code= (P1^P2^.....^P6)

3.1.1 Close Particle Measurement

Send: 16 07 01 00 00 00 10

Function: Close particle measurement

3.1.2 Open Particle Measurement

Send: 16 07 02 00 00 00 13

Function: Open particle measurement

3.1.3 Set Output Unit Send:

16 07 08 00 00 00 18

Function: Set output unit pcs/ m³

3.2 Read Data Command

Send by main controlled board:

START+READ+ACK+P1+ACK+P2+ACK+.....+P32+NACK+STOP

Data	Byte content	Description
Device address	Sensor address and read/write command	This byte is 0x51 when read data
P1	0x16	Frame header
P2	Frame length	Number of byte, not including length of device address (from P1 to P32, 32 bytes in total)
P3	Data 1	1: shut off 2.:Measuring 0x80 measurement completion 7: alarm
P4	Data 2	Output unit: 0: pcs/L 1:pcs/ m ³ 2: pcs/28.3L
P5	Data 3	Reserved: 0: continuous measurement mode 1: single accumulative counting mode
P6	Data 4	Alarm: same as alarm bit definition in UART
P7	Data 5	Calibration coefficient (range from 10 to 250, which corresponds to 0.1 to 2.5 coefficient)
P8	Data 6, high byte	>0.3 μm, particles number, unit: pcs/L(default), can be set as pcs/ m ³ or pcs/28.3L
P9	Data 6, high byte	
P10	Data 6, low byte	
P11	Data 6, low byte	
P12	Data 7, high byte	>0.5 μm, particles number, unit: pcs/L(default), can be set as pcs/ m ³ or pcs/28.3L
P13	Data 7, high byte	
P14	Data 7, low byte	
P15	Data 7, low byte	
P16	Data 8, high byte	>1.0 μm, particles number, unit: pcs/L(default), can be set as pcs/ m ³ or pcs/28.3L
P17	Data 8, high byte	
P18	Data 8, low byte	
P19	Data 8, low byte	
P20	Data 9, high byte	>2.5 μm, particles number, unit: pcs/L(default), can be set as pcs/ m ³ or pcs/28.3L
P21	Data 9, high byte	
P22	Data 9, low byte	
P23	Data 9, low byte	
P24	Data 10, high byte	>5.0 μm, particles number, unit: pcs/L(default), can be set as pcs/ m ³ or pcs/28.3L
P25	Data 10, high byte	
P26	Data 10, low byte	
P27	Data 10, low byte	
P28	Data 11, high byte	>10μm, particles number, unit: pcs/L(default), can be set as pcs/ m ³ or pcs/28.3L
P29	Data 11, high byte	
P30	Data 11, low byte	
P31	Data 11, low byte	
P32	Data check code	Check code = (P1^P2^.....^P31)

Accessories

Accessories PN	Picture	Description	Function
Gasboard-7500H-OPC		Ultrasonic Flow Meter	To measure air flow rate, measurement range is 0~5L/min

Package Information

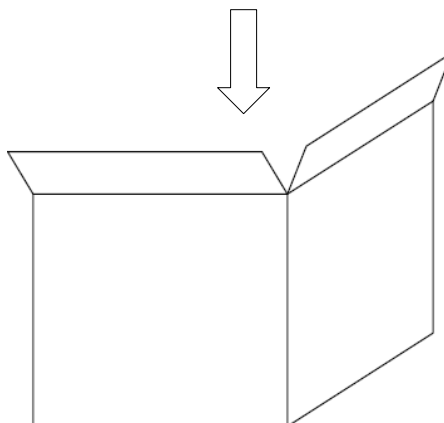
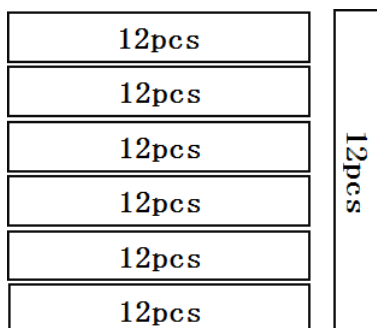
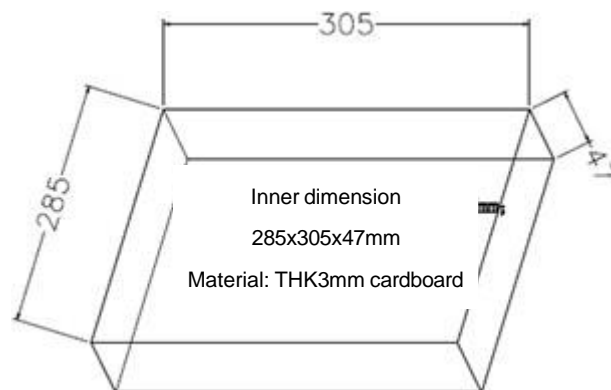
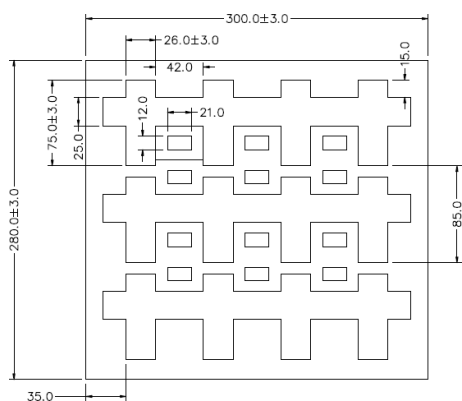

Sensor per Tray	Tray Qty	Sensor per Carton	Carton Dimensions	Packing Material
12 pcs	7 layers	84 pcs	W400*L300*H320 mm	Red anti-static EPE

Product Installation

When the sensor is installed and used in user's system, it should ensure that the airflow at the sensor's air inlet and outlet is unobstructed. To ensure sensor's measurement accuracy, the surface of sensor sensitive elements as shown in figure 1 shall be protected from dust depositing. It is recommended to install the sensor in user's system following the installation recommendation shown in figure 2.

Figure 1 Sensor Internal Profile

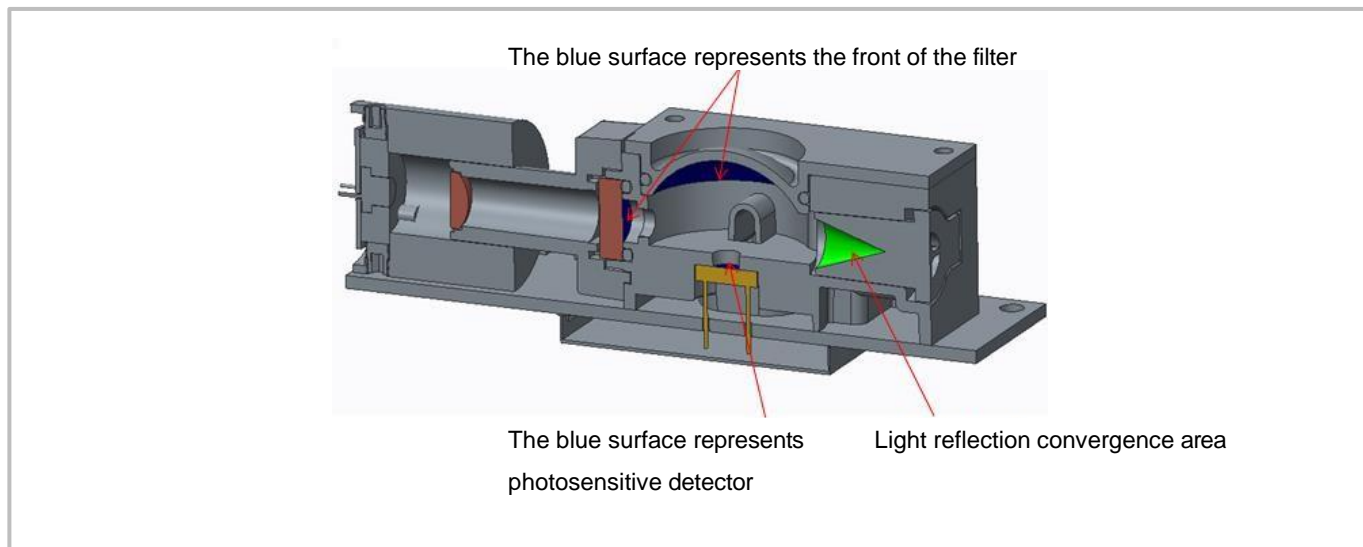
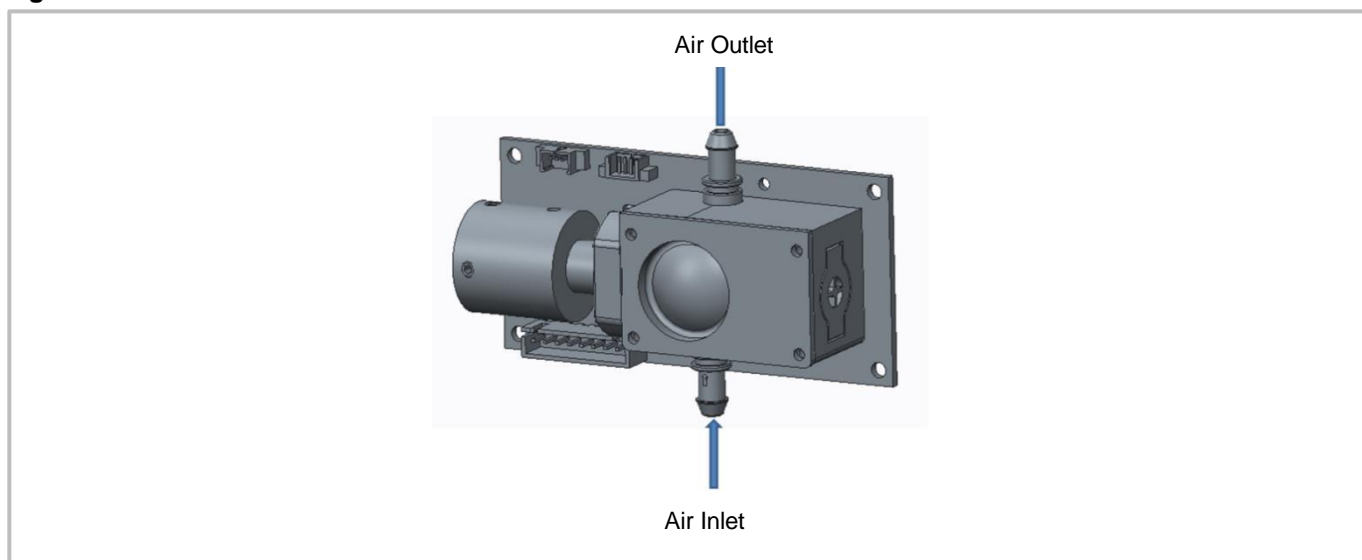

Figure 2 Installation recommendation



User Attentions

- ※ The recommended length of the air inlet duct should be within 20cm, and the recommended material is fluorine rubber.
- ※ It is recommended to use compressed air to clean the sensor regularly during the use of the product to prevent the contamination of flocs, hair, etc. from affecting the sensor detection.
- ※ The product is an integral part, users should not disassemble it to avoid irreversible damage.
- ※ The product is defined as a 3R laser product according to GB7247.1-2012 Laser Products Safety with laser radiation. Please avoid direct exposure to the eyed.



After-Sales Services and Consultancy

Cubic Sensor and Instrument Co., Ltd

Add: Fenghuang No.3 Road, Fenghuang Industrial Park, Eastlake Hi-tech Development Zone, Wuhan 430205, China

E-mail: info@gassensor.com.cn Tel:

+86 (0)27 81628827

Fax: +86 (0)27 81628821

Website: <http://www.gassensor.com.cn>