

SPECIFICATION

Product Name: AM4205 Series NDIR Refrigerant Sensor

Item No.: AM4205 Series

Version: V0.8

Date: October 17th, 2024

Revision

No.	Version	Content	Date
1	V0.1	Preliminary version	2023.08.01
2	V0.2	Added communication protocol	2023.08.31
3	V0.3	Added functionality of ABC cycle setting, operation hours record, heater switch and heater error status in communication protocol.	2023.09.04
4	V0.4	Update technical specifications: modify product weight	2024.4.26
5	V0.5	Update the sensor installation instructions picture	2024.5.07
6	V0.6	Update communication protocol: 1) Stop bit changed from 1 to 2; 2) Update table of error status.	2024.6.18
7	V0.7	Add certification instructions to the specification.	2024.07.01
8	V0.8	1) Update communication protocol: table of error status; 2) Update product images.	2024.10.17

AM4205 Series NDIR Refrigerant Sensor



Application

- Residential and commercial cooling
- Industry cooling and cold chain
- Residential and commercial heat pump
- Air conditioning system

Product Introduction

AM4205 Series Refrigerant Sensor is based on NDIR (Non-Dispersive Infrared) technology with high accuracy and longer lifespan. This sensor has been developed with standard gas and is efficiently calibrated in the factory by Cubic own gas sensor calibration technology. The sensing solutions can be easily integrated in safety and alarming devices.

Main Features

- NDIR (non-dispersive infrared) technology
- Matrix calibration to ensure accuracy
- Fast response ($T60_{@25\%LFL} \leq 30$ seconds)
- High selectivity, immune to poisoning gases
- Automatic heating mechanism for anti-condensation
- Maintenance free installation – reference channel and self-compensation, long-term stability, no false positives
- Long lifespan, 15+ years lifetime
- CE, RoHS, Reach, UL 60335-2-40 4th edition and IEC 60335-2-40 7th edition standard compliance

Principle of Measurement

Non-Dispersive Infrared (NDIR) Principle

Molecules like CH₂F₂ (R32) and other hydrocarbon components have specified absorption spectrum in infrared range. When light wave corresponded to certain gas with absorption spectrum passes through measured gas, the intensity of light wave will be significantly weakened. The intensity attenuation is related to concentration of measured gas. This relation follows Lambert-Beer's Law.

I stands for light transmissivity, $I = I_0 e^{-kpl}$

i stands for light absorption intensity, $i = I_0 - I = I_0 (1 - e^{-kpl})$

I_0 : incident light intensity

l : thickness of gaseous medium

p : gas concentration

k : absorption coefficient

AM4205 series NDIR refrigerant sensor is a dual-channel type with very high accuracy and good long-term stability. The basic principle of a dual-channel NDIR sensor is shown in the figure below:

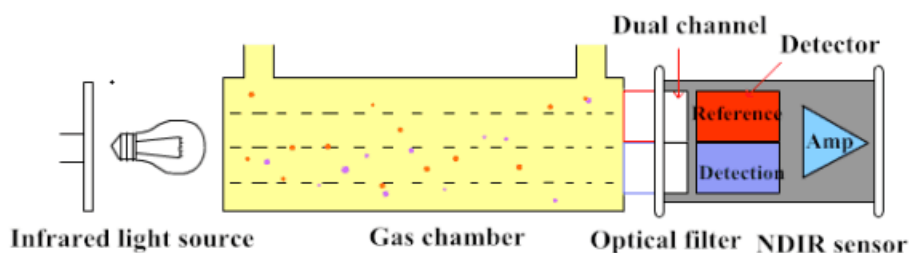

The infrared light source radiates infrared light which passes through the measured gas in the optical path and narrow band filters, then reaches the infrared detector. By measuring the intensity of the infrared light arriving at the infrared detector, the concentration of the measured gas can be calculated.

Technical Specifications

AM4205 Series Refrigerant Sensor Technical Specifications		
Basic performance	AM4205-LC	AM4205H-LC
Detecting principle	NDIR (non-dispersive infrared) technology	
Measurement gas ¹⁾	R32/R454A/R454B/R454C/R290	
Measurement range ²⁾	0~100% LFL	
Accuracy ³⁾	±2.5% LFL (@15%~25%LFL)	
Resolution	0.1% LFL	
Sampling frequency	1Hz	
Startup Time ⁴⁾	≤10s	
Response time ⁵⁾	T60≤30S@25%LFL	
Anti-condensation with heater ⁶⁾	No	Yes
Protection level	IP54	
Output	RS485 + Modbus	
Dimensions	76.8*59.2*19.5mm	
Weight	44.1g	
Lifetime	>15years, fault alarm before EOL will report	
Certification	Certified by IEC 60335-2-40:2022 Ed.7 and UL 60335-2-40:2022 Ed. 4.	
Environmental conditions		
Working temperature	-40~85℃	
Storage temperature	-40~85℃	
Working humidity	0-95%RH (non-condensing)	0-100%RH
Working pressure	80~110kPa (with pressure compensation)	
Electrical specifications		
Power supply	5±0.5V DC, ripple wave≤100mV	
Average Working Current ⁷⁾	≤100mA	≤380mA
Peak Current ⁷⁾	<250mA	<550mA

Remark:

1) For measurement of other refrigerant gases (R1234yf, R1234ze) please contact Cubic.

2) 100%LFL at 25℃ for each measurement gas (%Vol):

R32	R454A	R454B	R454C	R290
14.4%	8.4%	11.8%	7.9%	2.1%

3) For range 0~14.9%LFL, the maximum error is ±3.7LFL%, for range 25.1%LFL to 50%LFL, the maximum error is ±15% of reading. ABC (automatic baseline calibration) is default on with calibration cycle 7 days.

4) The sensor output is zero during 10s startup time.

5) At 25%LFL measurement gas environment.

6) A heater is used for anti-condensation function. (The test method is to move the sensor from 5℃ (95%RH) environment to 35℃ within 1 minute (condensing occurs). Under this condition, the heater is default on, and the sensor can keep stable and accurate measurement without influence

of condensation.)

- 7) The current is measured at room temperature condition, and it may vary at high temperature or low temperature condition.

Appearance Size & Pin Definition

1. Appearance Size

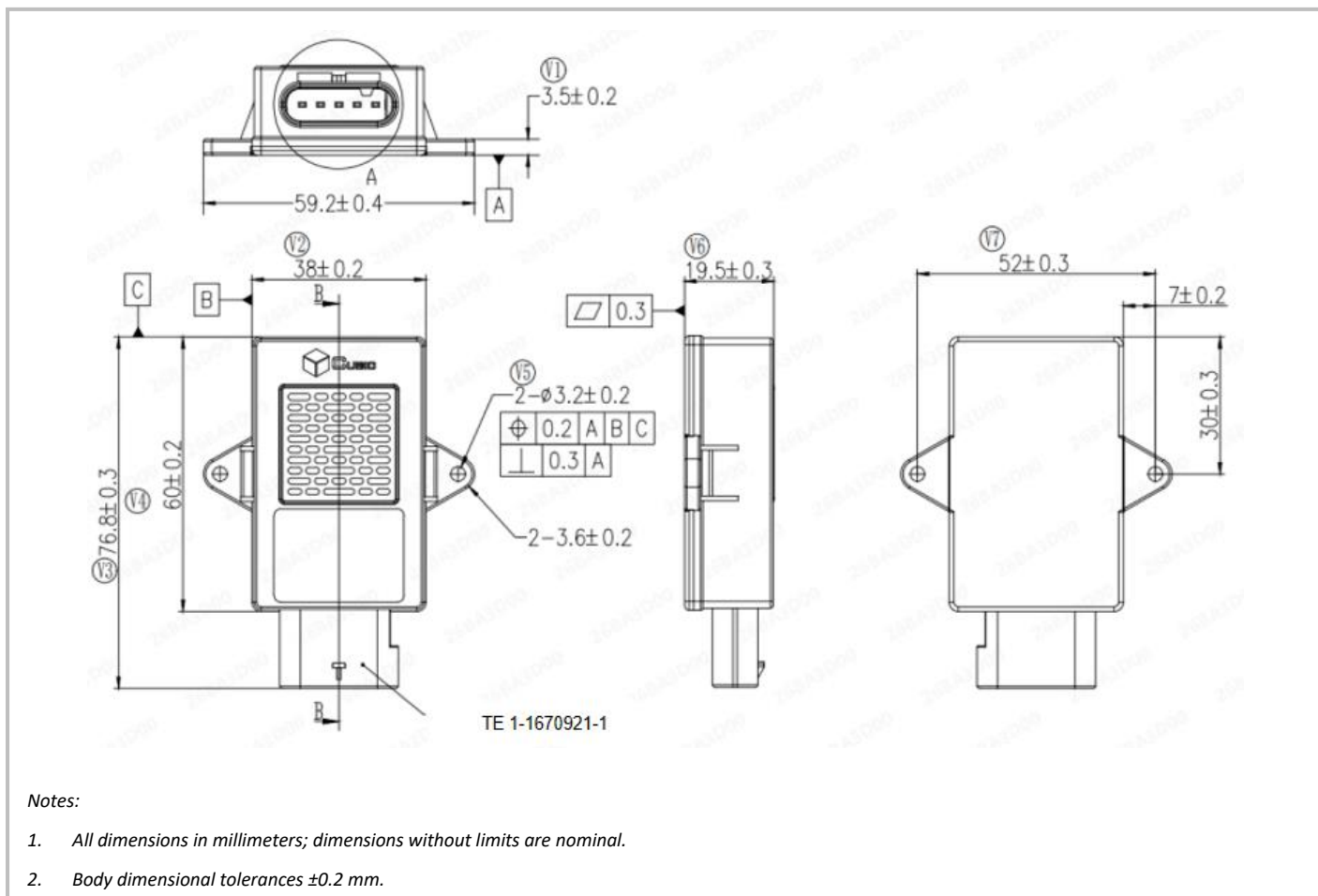

2. Pin Definitions

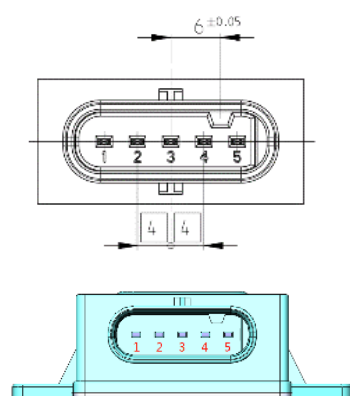

Pin	Name	Description
1	Power	Power input DC 5V
2	GND	Ground
3	B	RS-485 B
4	A	RS-485 A
5	NC	Not Connected

3. Connector Specification

Item	Part No.	Pin pitch
Match Connector	TE 1-1670921-1	4mm

Precautions for Use

1. Rated working temperature: $-40^{\circ}\text{C} \sim 85^{\circ}\text{C}$, for temperature out of this range please contact Cubic.
2. Connecting cables shall be shielded ones with insulating sheath with shielding layer grounded.
3. Users should not replace the components of this product without the professional guidance to avoid any irreversible damage. If need any technical supports, please contact Cubic.
4. Power supply voltage to the sensor should be within the rated value. A power supply lower than the rated voltage may cause the sensor to malfunction, while higher may cause permanent damage to the sensor.

Communication Protocol

1. Protocol Overview

The communication protocol uses the standard Modbus protocol in Modbus-RTU transmission mode. During the communication process, the sensor is always as a slave, responding to the master command sent by the host. The master communicates with the slave through RS-485 interfaces. The sensor can be communicated 3 seconds after powered on.

2. Serial Port Settings

Baud rate	Data Bit	Stop Bit	Parity	Flow Control
38400	8	2	None	None

3 Message Frame Format

Slave Device Address	Function Code	Data	CRC-16/MODEBUS
1 byte	1 byte	N bytes	2 bytes

3.1 Function Code

No.	Function Code	Operation	Description
1	0x03	Read holding registers	1 register includes 2 bytes
2	0x06	Write single register	1 register includes 2 bytes

3.2 Read Holding Registers(0x03)

Request		Response	
Field Name	HEX	Field Name	HEX
Slave Device Address	0x20~0x50	Slave Device Address	0x20~0x50
Function Code	0x03	Function Code	0x03
Starting Register Address High Byte	0x00~0xFF	Number of Data Bytes	0x00~0xFF
Starting Register Address Low Byte	0x00~0xFF	First Register Value High Byte	0x00~0xFF
Number of Registers High Byte	0x00~0xFF	First Register Value Low Byte	0x00~0xFF
Number of Registers Low Byte	0x00~0xFF
CRC Check Low Byte	0x00~0xFF	Last Register Value High Byte	0x00~0xFF
CRC Check High Byte	0x00~0xFF	Last Register Value Low Byte	0x00~0xFF
		CRC Check Low Byte	0x00~0xFF
		CRC Check High Byte	0x00~0xFF

3.3 Write Single Register(0x06)

Request		Response	
Field Name	HEX	Description	HEX
Slave Device Address	0x20~0x50	Slave Device Address	0x20~0x50
Function Code	0x06	Function Code	0x06
Register Address High Byte	0x00~0xFF	Register Address High Byte	0x00~0xFF
Register Address Low Byte	0x00~0xFF	Register Address Low Byte	0x00~0xFF
Register Value High Byte	0x00~0xFF	Register Value High Byte	0x00~0xFF
Register Value Low Byte	0x00~0xFF	Register Value Low Byte	0x00~0xFF
CRC Check Low Byte	0x00~0xFF	CRC Check Low Byte	0x00~0xFF
CRC Check High Byte	0x00~0xFF	CRC Check High Byte	0x00~0xFF

3.4 Detailed Register List

Register	Units/Value = Description	Read/Write	Register size	Data Type	Data Format	Register Address (Hex)
Percent LFL	% LFL (Multiplied by 100 to remove decimal)	READ ONLY	2 Bytes	Signed	Hex	0x00
Temperature	°C (Multiplied by 100 to remove decimal)	READ ONLY	2 Bytes	Signed	Hex	0x01
Gas Type	R32: 0x01 R454B: 0x02 R454A: 0x03 R454C: 0x04 R290: 0x05	READ ONLY	2 Bytes	Unsigned	Hex	0x02
Slave Address	default: 0x20 Range: 0x20-0x50	READ/WRITE	2 Bytes	Unsigned	Hex	0x03
Alarm Value	default: 15%LFL Range :1-100	READ/WRITE	2 Bytes	Unsigned	Hex	0x04
Error Status	See table of error status	READ ONLY	2 Bytes	Unsigned	Hex	0x05
Software Version	ASCII code of software version	READ ONLY	6 Bytes	Unsigned	Hex	0x06 - 0x08
Serial Number	ASCII code of serial number	READ ONLY	16 Bytes	Unsigned	Hex	0x09 - 0x10
ABC Cycle	Default: 7, unit: days Range: 0-240 0 means ABC is off	READ/WRITE	2 Bytes	Unsigned	Hex	0x11
Operation Hours	Range:0x0-0xFFFFFFFF Unit: hours	READ ONLY	4 Bytes	Unsigned	Hex	0x12 - 0x13
Heater Switch	0x00: OFF 0x01: ON Default: 0x01 (ON)	READ/WRITE	2 Bytes	Unsigned	Hex	0x14

Table of error status:

Status byte	Definition	Note
0x0000	Working normally	The sensor is working normally
0x0001	Power supply abnormal	Power supply >5.5V or <4.5V
0x0002	Working temperature abnormal	Working temperature >70°C or <-30°C
0x0004	Preheating	The sensor is in preheating process (10s after power on)
0x0008	Light source fault	The light source is not working normally
0x0010	Original signal abnormal	Abnormal sensor measurement signal
0x0020	Out of measurement range	Measured concentration is higher than 100% LFL
0x0040	Flash CRC error	Flash CRC error confirmed
0x0080	EEPROM CRC error	EEPROM CRC error confirmed
0x0100	RAM check error	RAM check error confirmed
0x0200	Sensor life expiration	The sensor needs to be replaced
0x0400	Sensor drift abnormal	Sensor drift concentration >15%LFL or <-15%LFL
0x0800	Sensor concentration alarm	Sensor concentration value greater than alarm concentration threshold
0x1000	Heating function abnormal	Heating function is not available

Note: Status bytes can appear cumulatively, indicating that two or more errors occur at the same time.

For example: 0x0820 means that the sensor concentration value is greater than the alarm concentration threshold and the measured concentration exceeds 100% LFL.

Product Code Instruction

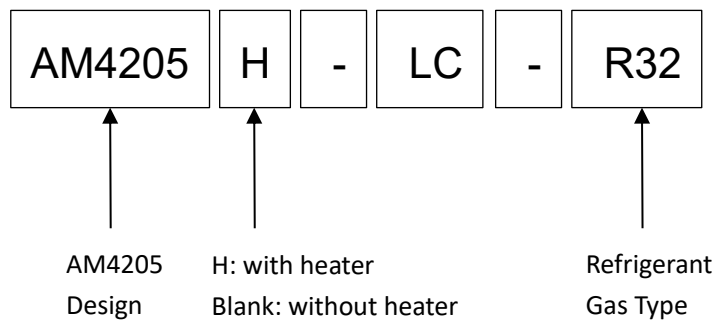

Sensor Installation Instruction

The recommended installation method is shown in the figure below. The terminal connector facing down and the design of shutter can prevent the sensor from dust accumulation, greatly reduce the influence of the sensor measurement by dust accumulation, and prolong the service life of the sensor.

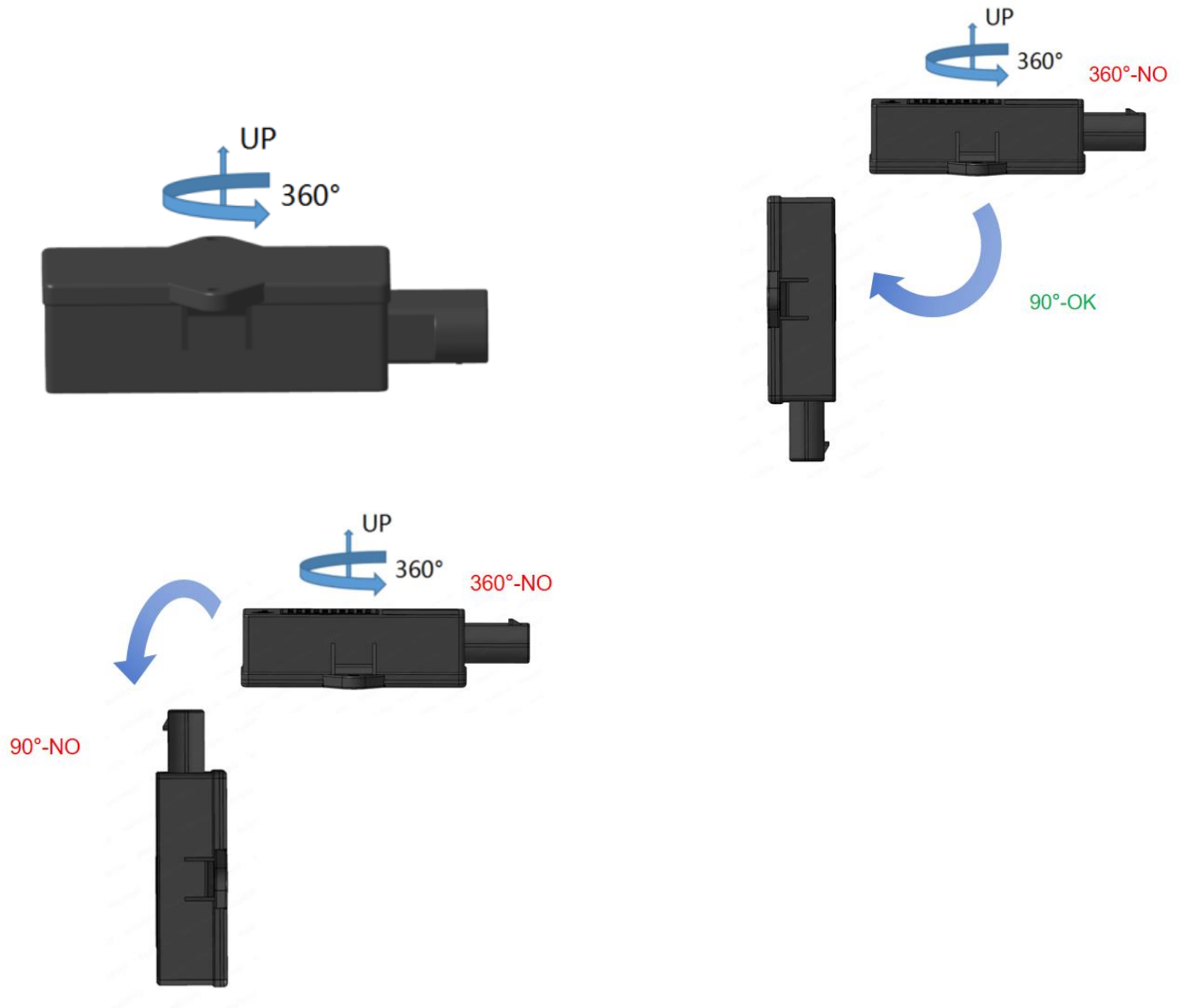

After-sales Services and Consultancy

Cubic Sensor and Instrument Co.,Ltd.

Tel: +86 (0)27 81628827 **Fax:** +86 (0)27 81628821

Add: Fenghuang No.3 Road, Fenghuang Industrial Park, Eastlake Hi-tech Development Zone, Wuhan 430205, China

E-mail: info@gassensor.com.cn