



Electrochemical Alcohol Sensor

# AL-03P (Premium type)



## Features

- Linearity
- Excellent Selectivity
- High sensitivity
- High reliability
- Perfect leak-proof structure
- Easy handling and direct soldering
- Small size

## Specifications

### Sensitivity Characteristics

Detection Gas	Alcohol (Ethanol)
Detection Range	0 ~ 2.0mg/L
Output Current	10 ~ 30 $\mu$ A
Repeatability	< $\pm$ 5%
Response Time	< 3.0seconds
Expected Life Time	3years <

Performance data conditions: 20°C, 50%RH and 1013mBar, under MGK SENSOR recommended conditions.

### Operating Conditions

Operating Temperature	0 ~ 50°C
Operating Humidity	10 ~ 90% RH
Recommended Absorption Volume	0.3cc
Recommended Absorption Time	0.4seconds
Position Sensitivity	None

### Storage Conditions

Temperature	-20 ~ 50°C
Recommended Storage Temperature	0 ~ 20°C
Storage period	6months in container

### Physical Characteristics

Cap Color	Black
Electric Pin	$\phi$ 0.45, Brass Au-plated
Weight	1.2 g (approx.)

## Appearance and Dimensions

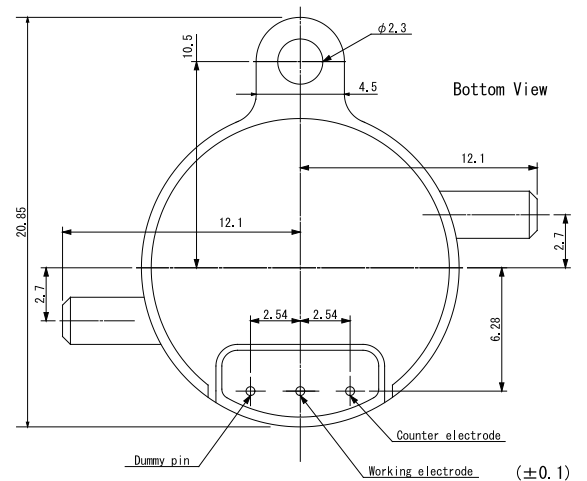
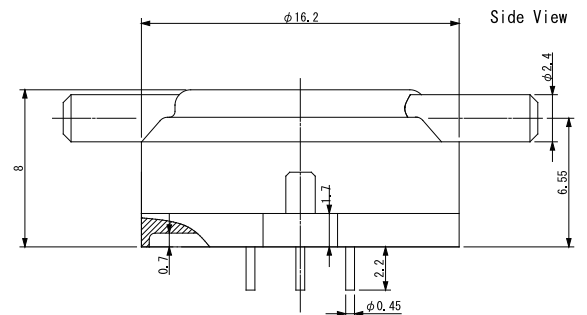

## Typical Selectivity

Test Gas	Gas Concentration (mg/L)	Typical Ethanol Concentration Equivalent (mg/L)
Ethanol	0.150	0.150
Carbon Monoxide	0.10	0.001
Acetone	0.25	0
Methanol	0.05	0.041
2-Propanol	0.05	0.023
Toluene	0.10	0

## Temperature dependency

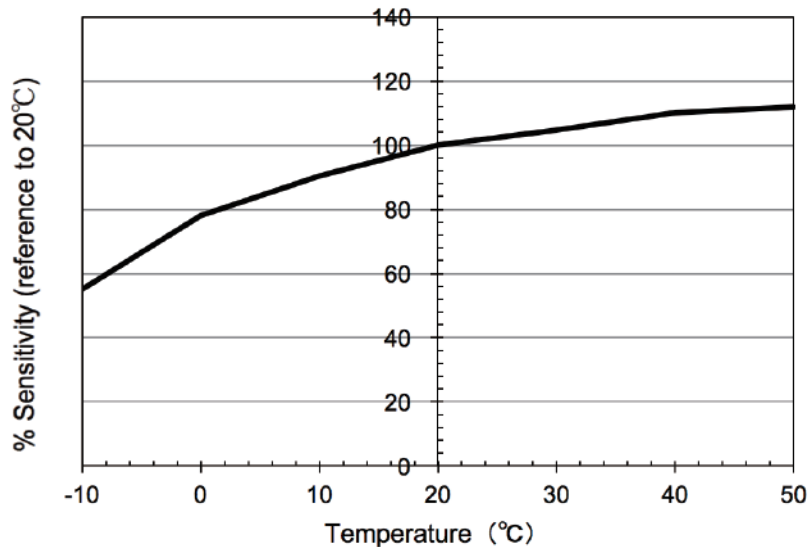
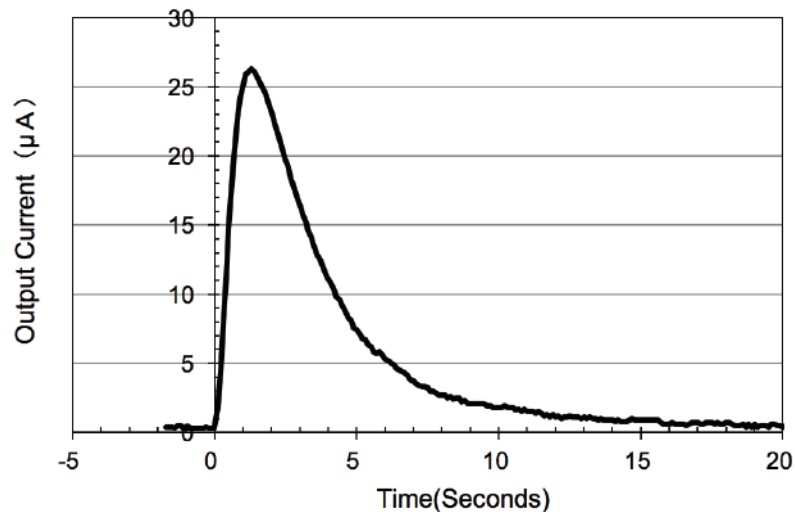

Fig. 2: Temperature dependency of AL-03P

## Typical Output signal



Conditions: Ethanol concentration 0.150 mg/L, Load resistor 10 Ω

**NOTE:** AL-03P DN-1011 Nov. 2017

As the products may be use outside control of MGK SENSOR, the information provided is given without legal responsibility. Customer should test under their own conditions, to ensure that the sensors are suitable for their own requirements.

In accordance with the company' s policy of continued product improvement, MGK SENSOR reserves the right to make product changes without notice.



**MGK SENSOR Co.,Ltd.** 2-190, Kagoharaminami, Kumagaya-shi, Saitama 360-0847, Japan

Tel.048-594-8518 Fax.048-594-8974 E-mail:info@mgk-sensor.co.jp <http://mgk-sensor.co.jp/>