

• Description

This is a Nitric Oxide (NO) gas sensor for monitoring and analysis of stack emissions or equivalent NO high concentration under harsh environmental conditions. It can be used to replace the standard 3 series electrochemical NO sensors produced by other manufacturers.

• Performance Characteristics

Nominal Range:	0 ~ 2,000 ppm
Maximum Overload:	5,000 ppm
Sensitivity (20°C):	0.10 ± 0.02 µA/ppm
Response Time (T90):	≤ 25 s
Zero Signal (20°C):	0 ~ +12 ppm
Baseline Shift (-20°C ~ 50°C):	< 30 ppm
Resolution:	1 ppm
Linearity:	Linear up to 2,000 ppm
Bias Voltage:	+300 mV

• Environmental

Temperature Range:	-20°C ~ 50°C
Pressure Range:	1 ± 0.1 atm
Humidity Range:	15% ~ 90%RH non-condensing

• Life Time

Long Time Output Drift:	< 2% signal/month
Recommended Storage Temp:	10°C ~ 30°C
Expected Operating Life:	3 years in clean air
Storage Life:	6 months in original packaging
Warranty:	12 months

• Intrinsic Safety Data

Max. Current at 5,000ppm NO:	< 1 mA
Max. O/C Voltage:	1.3 V
Max. S/C Current:	< 1.0 A

• Physical Characteristics

Housing Material:	ABS
Weight (Nominal):	23 g
RoHS Compliance:	Yes

• Installation

Output signals from the sensor pins are different. Inappropriate use of the pins in product design will affect the sensor functionality. When plugging or unplugging the sensor, align it vertically with the socket to avoid tilting or applying excessive force. Exposure to high concentrations of solvent vapors should be avoided under any condition. Mechanical overstress may cause deformation or cracks of the plastic enclosure of the sensor. If the sensor is used in extreme environmental conditions, please contact us for more details.

Website: www.semeatech.com
 E-mail: info_us@semeatech.com

• Product Dimensions

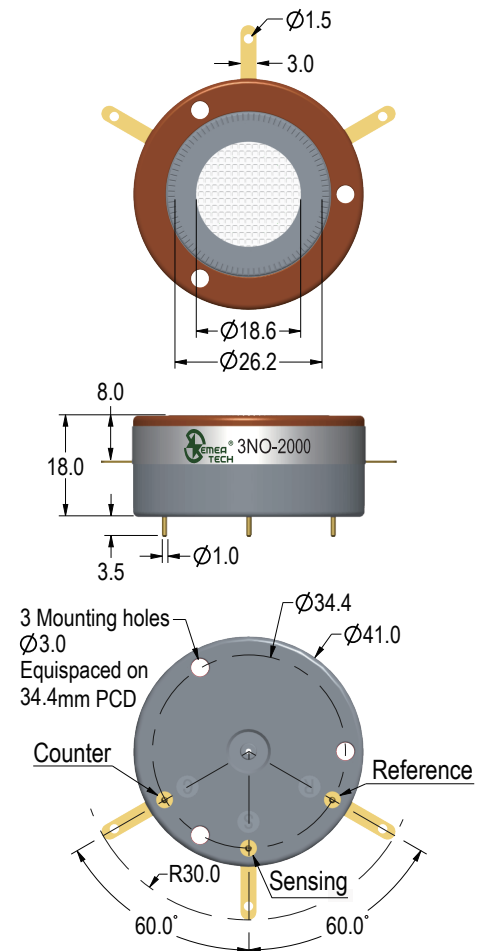

All dimensions in mm
 All tolerances ± 0.20 mm unless otherwise stated

• Note

The performance data in this document are conducted by using SemeaTech recommended test circuitry and test environment at 20°C, 50%RH and 1 atm. Sensor performance varies under different environmental conditions. Please contact us if you need more details.

• Cross-Sensitivity Data

Gas	Concentration (ppm)	Output Signal (ppm NO equivalent)
Sulfur Dioxide	100	0.2
Nitrogen Dioxide	90	5.0
Carbon Monoxide	500	-0.2
Hydrogen	200	0.2
Hydrogen Chloride	100	-0.5
Hydrogen Sulfide	200	0.4
Ethylene	200	0.4

Note: The cross sensitivities include but not limited to the above gases. It may also respond to other gases. The data in the table above may vary from different batches of sensors and the changes of test environment. Calibration using the gases that have the cross sensitivities to this sensor is not recommended.

• Temperature Data

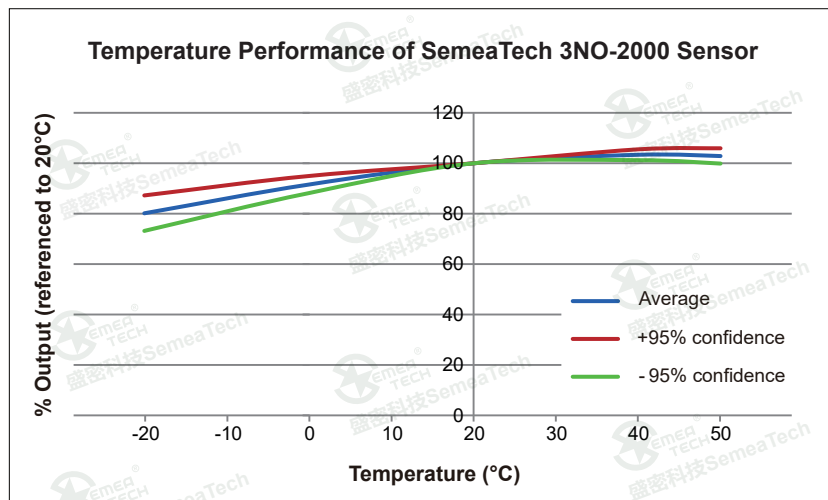

• Safety Note

This sensor is designed to be used in certain instruments for life critical applications. To ensure the sensor functions per its specifications inside the instrument, it is required to read the instrument user's guide carefully and comply with the calibration procedures by using certified target calibration gas before each use. Failure to do so may cause serious injury and fatality. Please do not open the sensor plastic enclosure because the electrolyte and other chemicals stored inside are harmful.

It is highly recommended for customers to validate the sensor performance using this document as a reference for their product designs or applications.

This product data sheet is used for reference only.

SemeaTech is committed to providing its customers the most accurate data based on its best knowledge. SemeaTech does not provide a product warranty for failures of using its products in accordance with product specifications that are described in the datasheet, or other misuses, abuse, negligence to the product.